

Operating Manual
DELTA SW4 - Long-Stroke
Single Seat and Change - Over Valve



Read and understand this manual prior to operating or servicing this product.



Declaration of Conformity for Valves and Valve Manifolds

APV Rosista GmbH, Zechenstr. 49, D-59425 Unna-Königsborn
as manufacturer with sole responsibility declares that the

**double seat valves of the series D2, SD4, SDT4, SDM4, SWcip4, DSV,
DA3, DE3, DEU3, DET3, DKR2, DKRT2, DKRH2**
in the nominal diameters DN 25 - 150, 1" - 6" and 1 Sh5 - 6 Sh5

butterfly valves of the series SV1 and SVS 1 F
in the nominal diameters DN 25 - 100, DN 125 - 250 and 1" - 4"

ball cocks of the series KH, KHV
in the nominal diameters DN 15 - 100

**single seat, diaphragm and spring loaded valves of the series
S2, SW4, SWmini4, SWT4, M3, MF3, M4, MF4, MP4, MS4, AP1, APT1, CPV, RG4,
RGM4, RGE4, RGEM4, PR2, PR3, PR4, SI2, UF3, VRA, VRAH**
in the nominal diameters DN 10 - 150, 1/2" - 4" and 1 Sh5 - 6 Sh5

and the valve manifolds installed thereof

meet the requirements of the Directives 89/392/EEC (amendment 93/44/EEC),
replaced by 98/37/EC and GSG - 9.GSGV.

For official inspections, APV Rosista GmbH presents
a technical documentation according to appendix V of the Machinery Directive,
this documentation consisting of documents of the development and construction,
description of measures taken to meet the conformity and to correspond with
the basic requirements on safety and health, incl. an analysis of the remaining risks
as well as an operating manual with safety instructions.

The conformity of the valves and valve manifolds is guaranteed.

D-59425 Unna-Königsborn, June 04, 2008
APV Rosista GmbH



Manager Research and Development

Table of Contents		Page
1.	General Terms	2
2.	Safety Instructions	2
3.	Mode of Operation	3
4.	Auxiliary Equipment	4
4.1	Valve position indication (PSH)	
4.2	CONTROL UNIT	
5.	Installation	5 - 6
5.1	Connections (threaded connections/clamp flange connections)	
5.2	Welding instruction	
6.	Dimensions / Weights	7 - 8
6.1	Single Seat Valve	
6.2	Change - Over Valve	
7.	Technical Data	9 - 11
7.1	General terms	
7.2	Opening and closing times SW4 - Long stroke	
7.3	Single Seat valve valve stroke / opening cross section	
7.4	Change Over Valve valve stroke / opening cross section	
7.5	Product pressure in bar	
7.6	DELTA SW4 - long stroke valve / air consumption	
8.	Maintenance	12
9.	Service Instruction Single Seat Valve	13 - 14
9.1	Dismantling from the line system	
9.2	Disassembly of wear parts (product-wetted parts)	
9.3	Installation of seals and assembly of valve	
9.4	Installation of valve	
10.	Service Instructions Actuator	15
10.1	Maintenance of actuator	
10.2	Installation of seals and assembly of actuator	
10.3	Actuator with valve position feedback	
11.	Service Instructions Change - Over Valve	16 - 17
11.1	Dismantling from the line system	
11.2	Disassembly of wear parts (product-wetted parts)	
11.3	Installation of seals and assembly of valve	
11.4	Installation of valve	
12.	Service Instructions	18
12.1	Assembly tool for seat seal	
13.	Trouble Shooting	19
14.	Spare Parts Lists	
14.1	Valve DN50-100 SW4 long-stroke	
14.2	Valve inch 2" -4" SW4 long-stroke	
14.3	Actuator SW4 long-stroke	
14.4	Valve position indication	

1. General Terms

This operating manual should be read carefully by the competent operating and maintenance personnel.

We point out that we will not accept any liability for any damage or malfunctions resulting from the non-compliance with this operating manual.

Descriptions and data given herein are subject to technical changes.

2. Safety Instructions



- Danger !

- The technical safety symbol draws your attention to important directions for operating safety. You will find it wherever the activities described are bearing risks of personal injury.
- Separate electric and pneumatic connections.
- **Depressurize** the line system before any maintenance work. Clean the valve if possible and drain residual liquids.
- **Do not reach into the open valve.**
Risk of injury by suddenly operating valve. In dismantled state there is the risk of bruising at movable parts of the valve.
- Observe service instructions to ensure safe maintenance of the valve.
- **Attention!**
Valve design NC (normally closed): Before releasing the housing clamp connection, the valve insert must be relieved by controlling the actuator.
- **Attention!**
Welded actuators are preloaded by spring force.



**Opening of the actuators is strictly forbidden.
Danger to life!**

Actuators which are no longer used and / or defective must be disposed in professional manner.

Defective actuators must be returned to your APV Solutions & Services company for their professional disposal and free of charge for you.

Please address to your local APV representative.

3. Mode of Operation

single seat valve

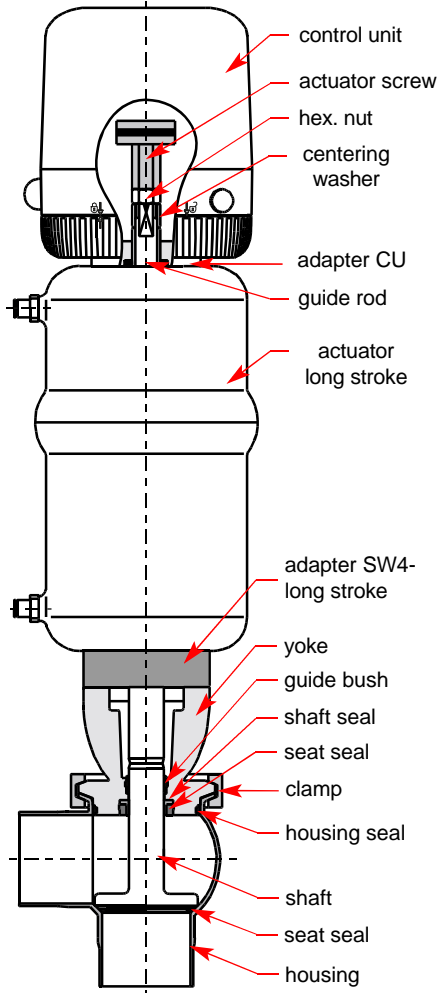

Single seat and change-over valves DELTA SW4 - Long Stroke have been developed for applications in the brewing and beverage, dairy and food industries as well as for chemical and pharmaceutical use.

The valves are designed for universal applications and stand out for their increased mechanical reliability and absolute ease of handling.

The function of the DELTA SW4 - long stroke valve is to shut off and to change over line sections in processes. The long stroke valve is used especially for high viscous and solids-containing liquids.

- Operation by pneumatic actuator with air connection, reset by spring force.
- By different assembly of the actuator, the following designs are possible:
 - NC:** actuator normally closed / air-to-raise, spring-to-lower
 - NO:** actuator normally open / air-to-lower, spring-to-raise
- The inner parts of the actuator need not be serviced.
- The cleaning of the inner valve is undertaken during CIP cleaning of the line system.
- The standard SW4 valve is equipped with a Control Unit DELTA CU 31.

The following different variants are possible:

- * Direct Connect
- * AS-Interface
- * DeviceNet
- * Profibus

- The yellow luminous diodes in the Control Unit indicate the position of the valve shaft.

change-over valve

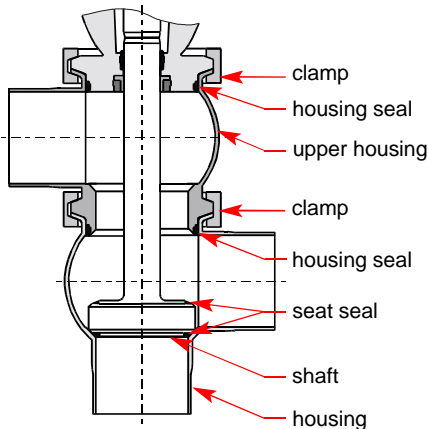

4. Auxiliary Equipment

fig. 4.1

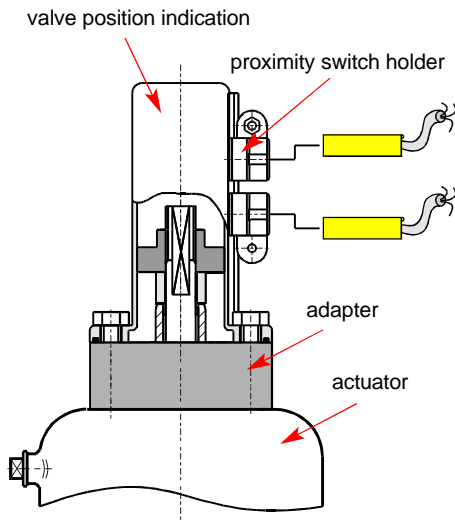

4.1 Valve position indication (PSH) fig. 4.1

- Alternatively to the Control Unit, the actuator can be equipped with a proximity switch holder (PSH) to indicate the valve position.
- For the assembly of the valve position indication on the DELTA SW4 long stroke valve in the dimensions DN80 - 100 / 3" - 4" an adapter is required.

adapter	
designation:	adapter SW4 165 PSH lang stroke
ref.No.:	08-48-360/93

Proximity switches to signal the limit position of the valve seat can be installed at the proximity switch holder if required.

We recommend to use our APV standard type:

Three-wire proximity switch

Operating distance: 5mm / diameter: 11mm

Operating voltage: 10 - 30 V DC

pnp positive switching, closing function

Installation „non-flush"

Using a valve position indicator other than APV, we cannot accept any liability for a faultless function.

fig. 4.2

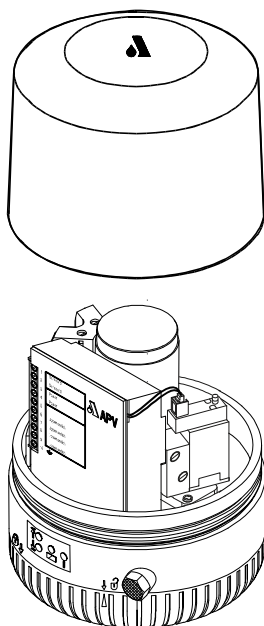

4.2 CONTROL UNIT (fig. 4.2)

For the start-up as well as assembly and disassembly of the different designs please use the respective manual.

The following different designs are available:

solenoid valves (SV)	
Direct Connect ref.No.:	CU31 Direct Connect 16 - 31 - 232/93
Profibus ref.No.:	CU31 Profibus 08-45-001/93
Device Net ref.No.:	CU31 Device Net 16 - 31 - 240/93
AS-interface 2.1 ref.No.:	CU31 AS-interface 2.1 08 - 45 - 020/93

- For the assembly of a control unit on the DELTA SW4 long-stroke valve an adapter is required.

adapter	
designation:	CU3 - adapter SW4 / M4
ref.No.:	08 - 48 - 480/93

5. Installation

fig. 5.

change-over valve

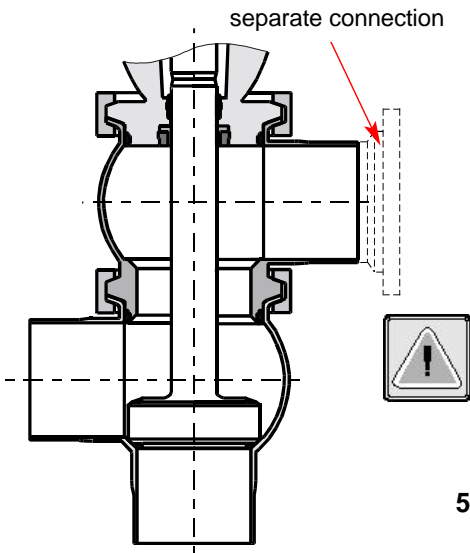

- The installation of the valve must be undertaken in such a manner that fluids can drain off the valve housing and should be provided preferably in vertical position.
- **Single seat valve :** The valve housing can be welded direct into the pipeline (completely dismantable valve insert).
- **Change-over valve :** Through a flange or clamp connection, the upper housing of change-over valves is detachable from the pipeline. (see fig 5).
- **Attention :** **Observe welding instructions.** (see chapter 5.2)

5.1 Connections:

Besides the housings with weld ends, the following connections are alternatively available:

- male part to DIN 11851
- male part IDF / ISS to ISO 2853
- male part RJT to BS 4825-5
- male part SMS
- male part to DS 722
- flange connection FGN1 DIN
- flange connection FGN1 Zoll
- clamp connection to DIN 32676
- clamp connection to ISO 2852

5. Installation

5.2 Welding instructions

Single seat valve:

- Before welding of the valve, the valve insert must be dismantled from the housing. Careful handling to avoid damage to the parts is necessary.

Change-over valve:

- Before welding of the valves, the valve insert must be dismantled from the housing. The lower housing seal must be removed. Careful handling to avoid damage to the parts is necessary.
- Welding should only be carried out by certified welders (EN 287-1). (Seam quality EN 25817 "B").
- The welding of the valve housings must be undertaken in such a way that the valve body is not deformed.
- The preparation of the weld seam up to 3 mm thickness must be carried out as a square butt joint without air. (Consider shrinkage!)
- TIG orbital welding is best!
- After welding of the valve housings or of the mating flanges and after work at the pipelines, the corresponding parts of the installation or pipelines must be cleaned from welding residues and soiling. If these cleaning instructions are not observed, welding residues and dirt particles can settle in the valve and cause damage.
- Any damage resulting from the non-observance of these welding instructions is not subject to our guarantee.

6. Dimensions / Weights

6.1 single seat valve

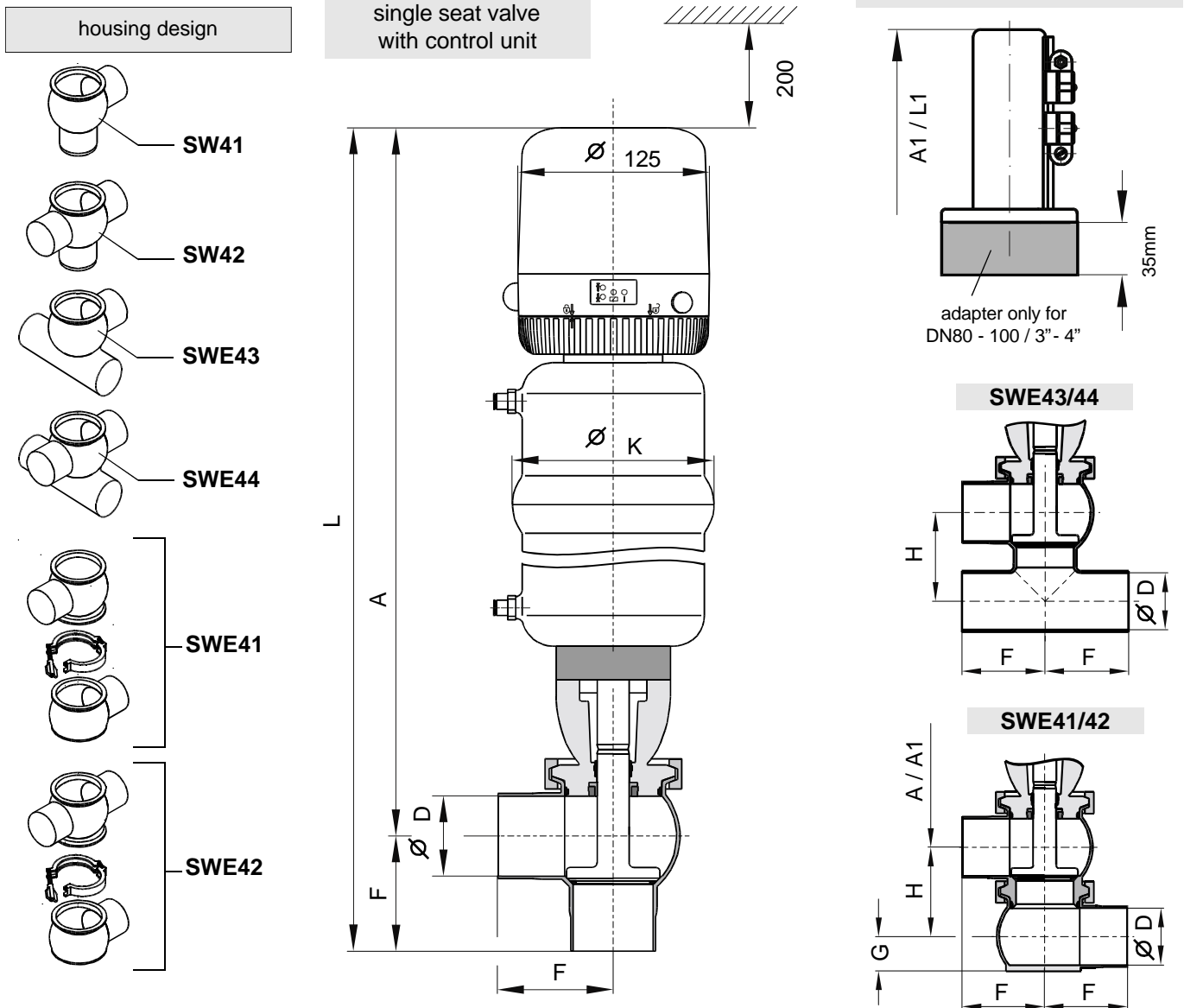

dimensions in mm

DN	Ø D	F	Ø K	A	L	A1	L1	G	H	weight in kg
50	50	72	126	511	583	451	523	32	78	10
65	66	85	126	519	604	459	544	40	94	10
80	81	98	189	654	752	629	727	47,5	109	18
100	100	111	189	674	785	649	760	57	128	20
Inch										
2"	47,6	72	126	510	582	450	522	30,8	75,6	10
2,5"	60,3	85	126	516	601	456	541	37,2	88,3	10
3"	72,9	90	189	649	739	624	714	43,5	100,9	18
4"	97,6	111	189	672	783	647	758	55,8	125,6	20

6. Dimensions / Weights

6.2 change-over valve

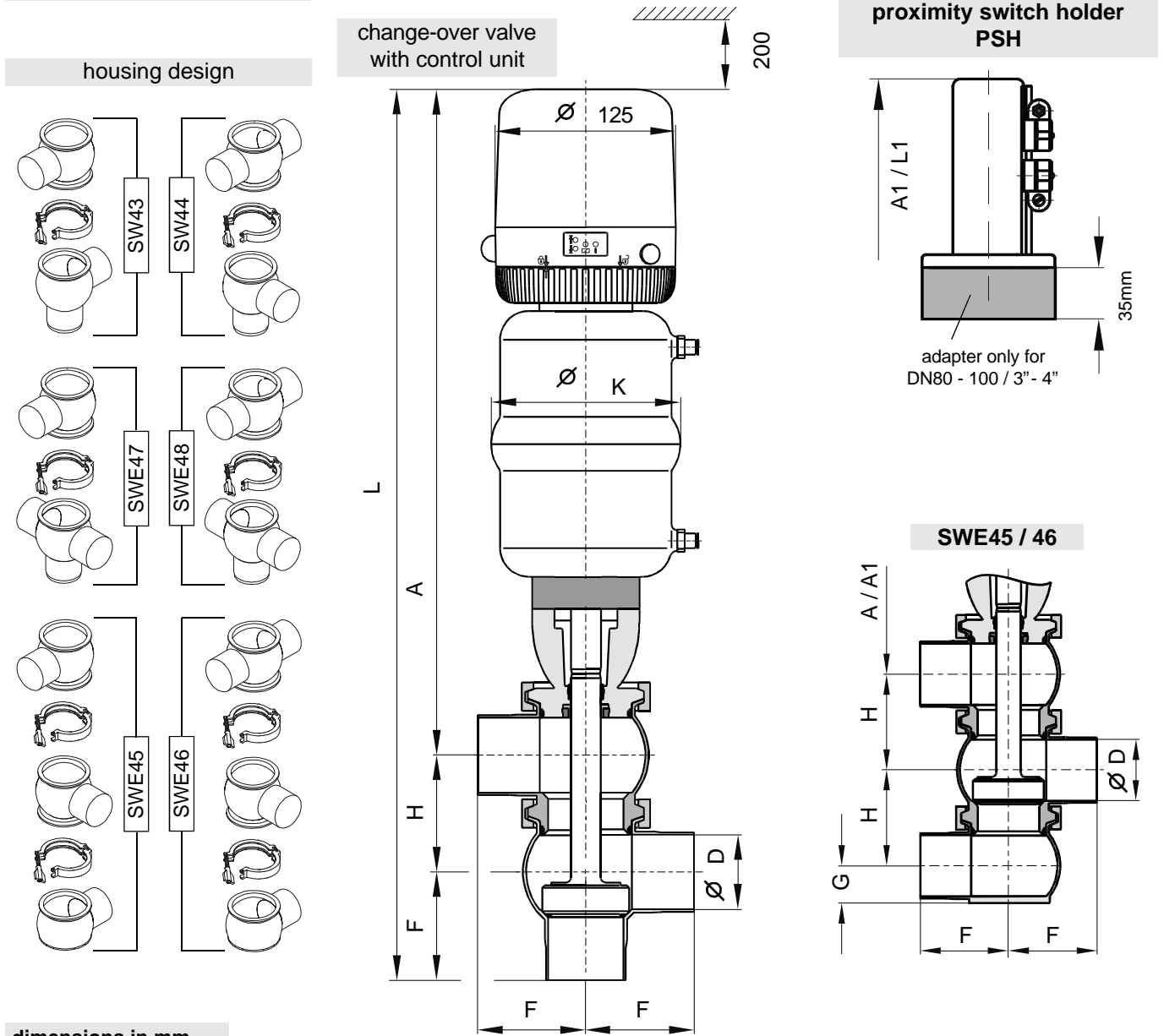

dimensions in mm

DN	Ø D	F	Ø K	A	L	A1	L1	G	H	weight in kg
50	50	72	126	511	661	451	601	32	78	11
65	66	85	126	519	698	459	638	40	94	11
80	81	98	189	654	861	629	836	47,5	109	20
100	100	111	189	674	913	649	888	57	128	22
Inch										
2"	47,6	72	126	510	657	450	597	30,8	75,6	11
2,5"	60,3	85	126	516	689	456	629	37,2	88,3	11
3"	72,9	90	189	649	840	624	815	43,5	100,9	20
4"	97,6	111	189	672	909	647	884	55,8	125,6	22

7. Technical Data

7.1 General terms

product - wetted parts :	316 L, 1.4404
other parts :	1.4301
seals :	standard design : EPDM
optional :	FPM, VMQ, HNBR
max. product pressure :	10bar
max. operating temperature :	135°C EPDM, HNBR *FPM, *VMQ
short-term load :	140°C EPDM, HNBR *FPM, *VMQ *(no steam)
air connection (for hose) :	6x1mm
max. pneumatic air pressure :	8 bar
min. pneumatic air pressure :	6 bar

(Use dry and clean pneumatic air, only)

7.2 Closing times for single seat and change-over valves DELTA SW4 long stroke. The opening and closing times of the valves with control unit can be fixed by adjusting the throttle screw at the solenoid valve			
		closing times in sec. air pressure 6 bar	
		hose length	
DN	Inch	1m	10m
50	2"	5	6
65	2,5"	6	7
80	3"	9	10
100	4"	10	11

7. Technical Data

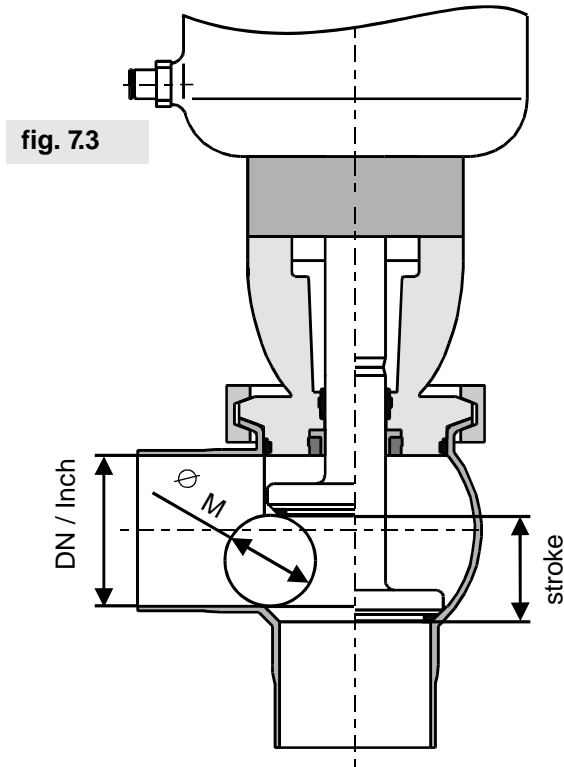

fig 7.3 valve stroke / opening cross section in mm		
single seat valve SW41,42 SWE41,42,43,44		
DN	Hub	Ø M
50	36	31
65	48	43
80	62	58
100	72	67
inch		
2"	36	31
2,5"	48	43
3"	62	58
4"	72	67

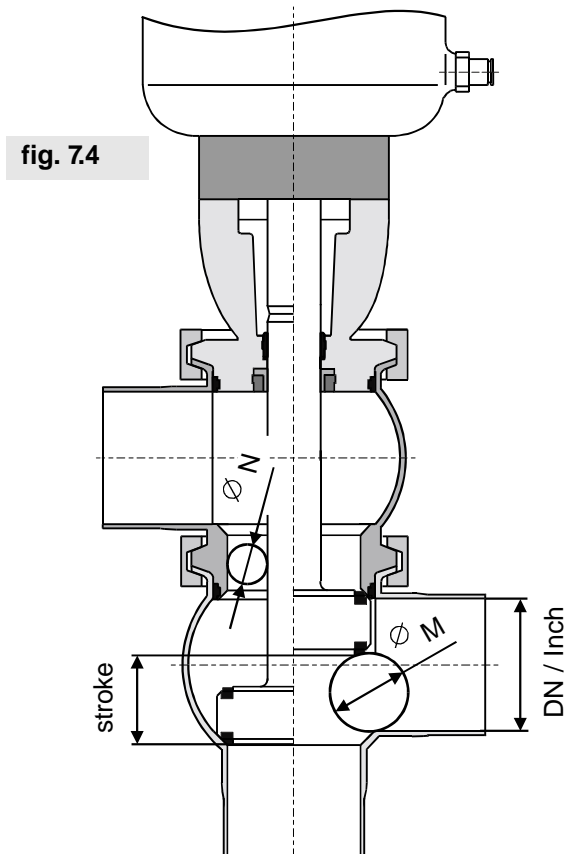

fig 7.4 valve stroke / opening cross section in mm			
change-over valve SW43,44,47,48 SWE45,46			
DN	stroke	Ø M	Ø N
50	33	31	15
65	45	43	23
80	59	58	30,5
100	69	67	40
Inch			
2"	33	31	15
2,5"	45	43	20
3"	59	58	26,5
4"	69	67	40

7. Technische Daten

7.5 DELTA SW4 calculatory product pressure in (bar) at 6 bar air pressure

DN / Inch	∅ actuator in mm		∅ actuator in mm		∅ actuator in mm		∅ actuator in mm	
	∅ 110	∅ 165	∅ 110	∅ 165	∅ 110	∅ 165	∅ 110	∅ 165
50 / 2"	7,6		7,1		8,3		8,8	
2,5"	5,4		5,0		5,5		6,0	
65	5,0		5,0		5,0		5,0	
3"		9,9		8,5		9,1		10,6
80		7,9		6,8		7,2		8,4
100 / 4"		5,3		5,0		5,0		5,5

7.6 DELTA SW4 - long-stroke valve air consumption

Air consumption in normal liter / NL at 6 bar air pressure			
DN	Inch	actuator ∅110	actuator ∅165
50	2"	3,1	
65	2,5"	3,1	
80	3"		10,5
100	4"		10,5

8. Maintenance

- The **maintenance intervals** depend on the corresponding application and are to be determined by the operator himself carrying out **temporary checks**.
- The valve must not be cleaned with products containing abrasive or polishing material.
Especially the valve shaft must not, under any circumstances, be cleaned with such agents.
Damage of the valve shaft can lead to leakages.



- Required tools :
 - 1x hexagon socket screw key 6mm
 - 1x wrench SW13
 - 1x wrench SW17
 - 1x wrench SW19
 - 1x wrench SW30
 - 1x strap wrench
- Assembly tool for seat seal (see chapter 12.)
- Cleaning rag as well as a dilute solution of a suitable cleaning liquid.
- Exchange of seals is carried out according to service instructions.
A customer stock keeping of spare seals is recommended.
For the valve service we supply complete seal kits including seal grease (see spare parts lists).
- Assembly of the valve and change of the valve design **NC or NO** according to service instructions.
- **Slightly grease all seals before their installation !**

Recommendation:

APV food-grade-grease for EPDM, HNBR, FPM and NBR

(0,75 kg/tin - ref.-No. 000 70-01-019/93)

(60 g/tube - ref.-No. 000 70-01-018/93)

or

APV food-grade-grease for VMQ

(0,6 kg/tin - ref.-No. 000 70-01-017/93)

(60 g/tube - ref.-No. 000 70-01-016/93)

- !!! Do not use grease containing mineral oil for **EPDM** seals.
- !!! Do not use Silicone-based grease for **VMQ** seals.

9. Service Instructions Single Seat Valve

single seat valve

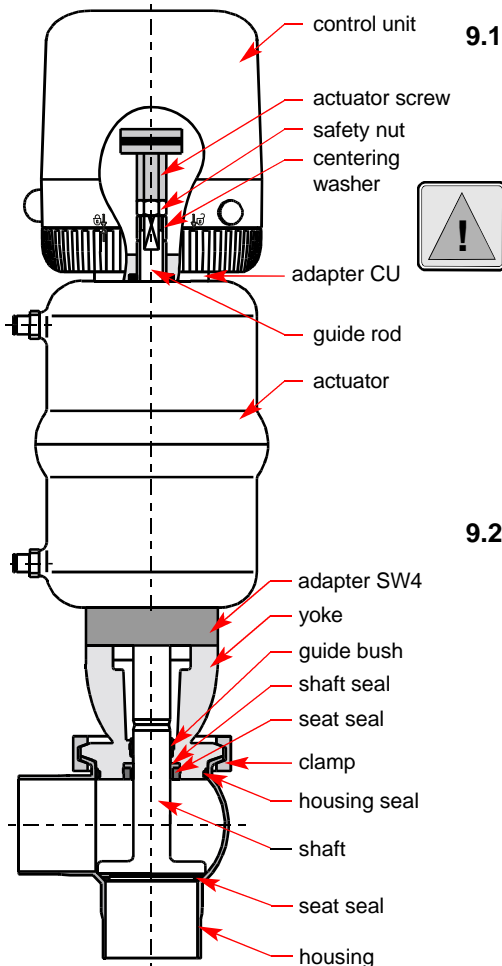

9.1 Disassembly from the line system

a. Shut off the line pressure and the drain lines if possible.

b. **Valve design NC: Control actuator with air.**

Do not touch movable valve parts!
Risk of injury.

c. Detach the clamp and lift the valve insert off the housing.

d. Shut off compressed air and remove the compressed air supply.

e. Take the Control Unit off the actuator.
(Turn ring in anti-clockwise direction.)

9.2 Dismantling of wear parts (product-wetted parts)

a. Remove the housing seal.

b. Release the actuator screw from the guide rod.
Remove the CU adapter.

c. Release the safety nut by holding up the centering washer,
remove the centering washer.

d. Pull the valve shaft out of the actuator. Remove the seat seal.

e. **Dimensions DN 50 - 65 / 2" - 2,5" :**
Unscrew the yoke with SW4 long-stroke adapter from the actuator.
- **Dimensions DN 80 - 100 / 3" - 4" :**
Unscrew the yoke from the adapter SW4 long-stroke adapter.
(The SW4 long-stroke adapter is screwed separately with the actuator).

f. Detach the seat seal, shaft seal and the guide bush.

Maintenance of the actuator see chapter 10.1

9. Service Instructions Single Seat Valve

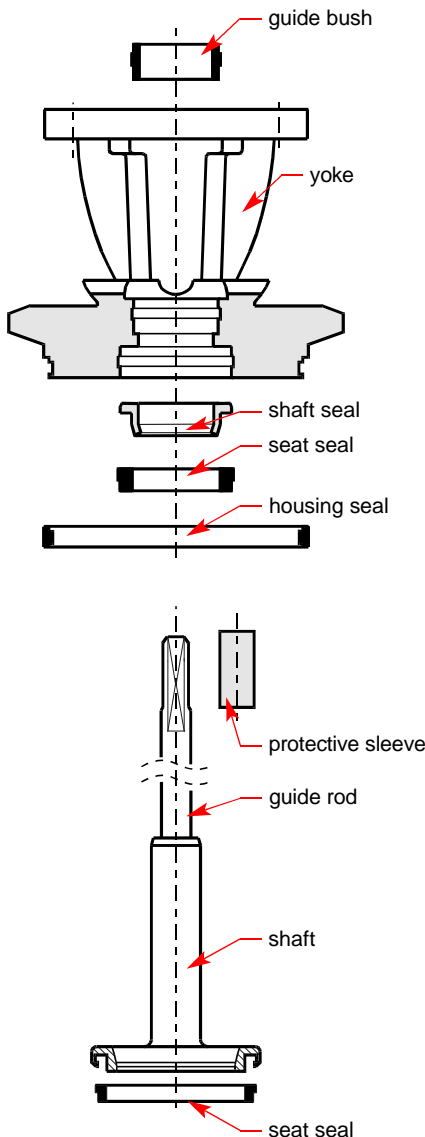

9.3 Installation of the seals and assembly of the valve

- a. Insert the guide bush into the yoke. Afterwards, insert the shaft seal and press in the slightly greased seat seal.
See to the correct installing position.
- b. **Dimensions DN 50 - 65 / 2" - 2,5" :**
Install the yoke with SW4 long-stroke adapter at the actuator.
- **Dimensions DN 80 - 100 / 3" - 4" :**
Install the yoke at the SW4 long-stroke adapter.
- c. Insert the seat seal into the shaft. Use the assembly tool to install the seat seal (**see chapter 12**). Grease the seat seal only slightly before its installation. In case of manual installation, vent the seal groove with a thin object between the seal and the groove wall.
- d. Install the protective sleeve via the thread of the guide rod. Slide the shaft through the yoke, adapter SW4 and actuator, place the centering washer and tighten it with the safety nut. Hold up the centering washer during this process.
Tightening torque 40 Nm.
- e. Slightly grease the housing seal and place it in the groove of the yoke.
- f. Install the adapter for the Control Unit on the actuator. Apply a drop of a screw locker (e.g. type: Loctite semi-solid) in the area of the threaded bore of the actuator screw. Fasten the actuator screw on the guide rod.

9.4 Installation of the valve

- a. Place the control unit on the adapter and secure it with the ring.
- b. Connect the compressed air supply.
- c. **Valve design NC : Control actuator with air**



Do not touch movable valve parts!
Risk of injury by sudden valve operation.

- d. Place the valve insert carefully into the housing and fasten the clamp.
The housing seal must not be damaged during the installation.
- e. **Valve design NC: Shut off air.**
- f. **Check the basic adjustment of the valve position indicator.**
 - The shift points can be adjusted by turning the positioning screw in the control unit.

10. Service Instruction Actuator

10.1 Maintenance of the actuator

- a. Remove the air hoses from the actuator.
- b. Remove the inner hexagon screws from the adapter of the Control Unit. Lift the adapter of the control unit.
- c. **Dimensions DN80 - 100 / 3" - 4":**
Remove the inner hexagon screws from the SW4 long-stroke adapter. Lift the adapter.
- d. Unscrew the two seal screws with a spanner SW30 while holding up the actuator with a strap wrench.

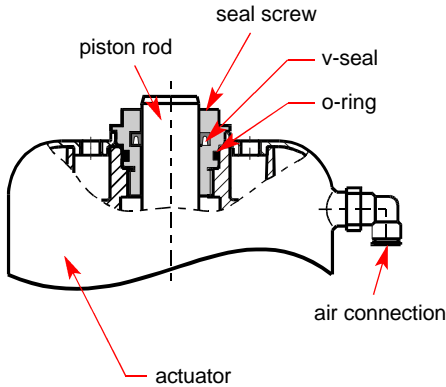

fig. 10.2

10.2 Installation of seals and assembly of actuator

- a. Install the greased o-rings and v-seals in the seal screws (fig. 10.2) **See to the correct installing direction of the v-seal.**
- b. Slide the seal screws over the piston rod at both sides of the actuator and tighten them.
- c. Fasten the adapter for the Control Unit and the yoke on the actuator.

Attention: Observe position of adapter.

Attention: Consider the required valve design NC or NO during the installation of the adapter and yoke.
NC = normally closed / air-to-raise, spring-to-lower
NO = normally open / air-to-lower, spring-to-raise

- d. **Valve dimensions DN80 - 100 / 3" - 4" only:**
Install the SW4 long-stroke adapter with the inner hexagon screws on the actuator.
- e. Fasten the air hoses.

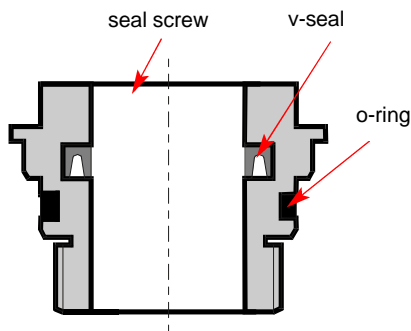
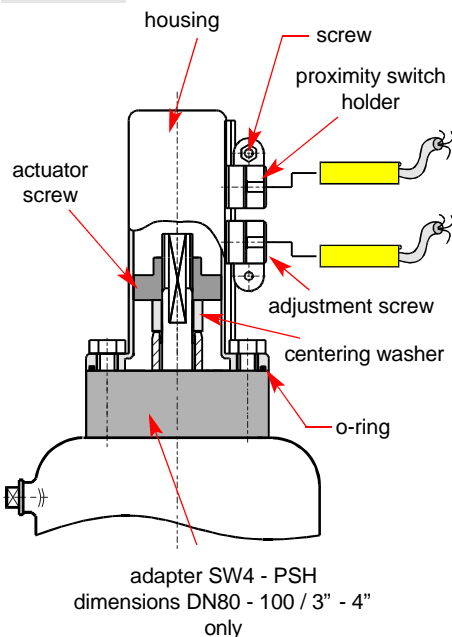

fig. 10.3

10.3 Actuator with the valve position indicator (PSH) Assembly of the holdres (fig. 10.3)

1. Install the actuator screw on the actuator.
2. Equip the housing with the o-ring.
3. Fasten the housing by means of the 4 hex. screws M8x16 on the actuator.
- Dimensions DN80 - 100 / 3" - 4" : fasten the adapter with housing by means of the hexagon screws M8 x 50.
4. Release the screws at the proximity switch holder and insert the corresponding proximity switches. Then fasten the screws.
5. Place the actuator in one limit position.
6. Place the corresponding proximity switch in the corresponding position. Release the positioning screw and move the holder until the corresponding signal is indicated. Then continue the movement by 2 to 3 mm to secure the indication. Fasten the positioning screw.
7. Place the actuator in the other limit position and carry out positioning of the second proximity switch.



11. Service Instruction Change - Over Valve

change-over valve

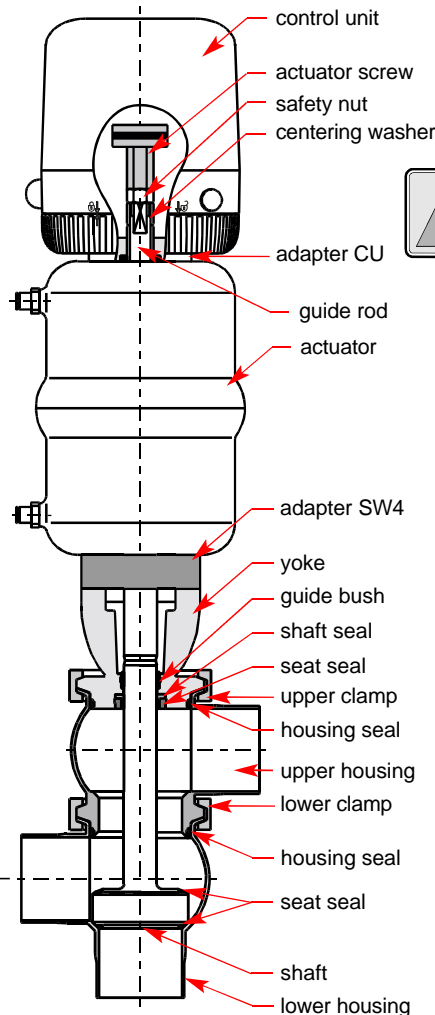

11.1 Dismantling from the line system

- a. Shut off the line pressure and the drain lines if possible.
- b. Release the connection between the upper housing globe and the connected line.

c. Valve design NC: Control actuator with air.

**Do not touch movable valve parts!
Risk of injury.**

- d. Remove the lower clamp.
- e. Lift the valve insert together with the upper housing off the lower housing.

**f. Attention: Valve design NC:
Shut off compressed air and remove the compressed air supply.**

- g. Take the Control Unit from the actuator.
(Turn ring in anti-clockwise direction).

11.2 Dismantling of product-wetted parts

- a. Unscrew the actuator screw from the guide rod.
Dismantle the CU adapter.

**b. Attention: Valve design NC:
Control valve with pneumatic air.**

- c. Unscrew the safety nut, while holding up the centering washer, remove the centering washer.

**Attention: Valve design NC:
Shut off valve with pneumatic air.**

- d. Take the shaft out of the actuator and remove the seat seals.
- e. Detach the upper clamp and upper housing.
Remove the two housing seals.
- f. **Dimensions DN 50 - 65 / 2" - 2,5" :**
Unscrew the yoke with SW4 long-stroke adapter from the actuator.
- **Dimensions DN 80 - 100 / 3" - 4" :**
Unscrew the yoke from the SW4 long-stroke adapter.
(The SW4 long-stroke adapter is screwed separately with the actuator).
- g. Take off the seat seals, shaft seal and guide bush.

Maintenance of the actuator see chapter 10.1

11. Service Instruction Change - Over Valve

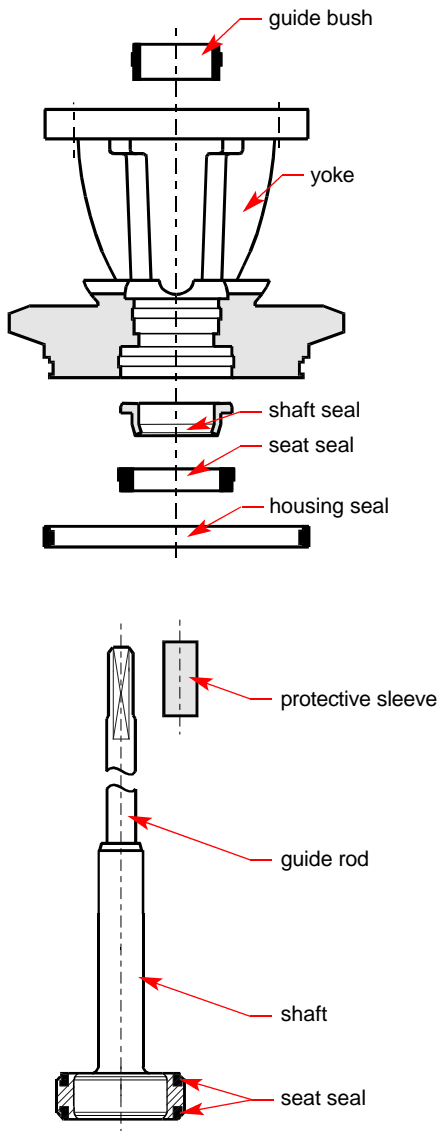

11.3 Installation of seals and Assembly of valve

- a. Insert the guide bush into the yoke. Then place the shaft seal, press in the slightly greased seat seal. See to the correct installing position.
- b. **Dimensions DN 50 - 65 / 2" - 2,5" :**
Install the yoke with SW4 long-stroke adapter at the actuator.
- **Dimensions DN 80 - 100 / 3" - 4" :**
Install the yoke at the SW4 long-stroke adapter.
- c. Insert the seat seal in the shaft. Use the APV assembly tool to install the seat seal, see chapter 12. Grease the seat seal only slightly before its installation. In case of manual installation, vent the seal groove with a thin object between the seal and the groove wall.
- d. Slightly grease the housing seals and install them in the grooves of the yoke and of the upper housing. Fasten the upper housing at the yoke by means of the clamp.

**Attention: Valve design NC:
Control the valve with air.**

- e. Slide the protective sleeve over the thread of the guide rod. Slide the shaft through the upper housing, SW4 adapter, yoke and actuator. Place the centering washer and tighten the safety nut. Hold up the safety washer during this process.
Tightening torque 40 Nm.
- f. **Attention: Valve design NC:
Shut off pneumatic air.**
- g. Install the Control Unit adapter on the actuator. Apply a drop of a screw locker (e.g. type: Loctite semi-solid) in the area of the threaded bore of the actuator screw. Screw the actuator screw on the guide rod.

11.4 Installation of the valve

- a. Place the Control Unit on the adapter and secure it with the ring.
- b. Connect the compressed air supply.
- c. **Valve design NC: Control the actuator with air.**



**Do not touch movable valve parts!
Risk of injury by sudden valve operation.**

- d. Place the valve insert carefully into the lower housing and fasten the lower clamp. The housing seals must not be damaged during this installation.
- e. **Valve design NC: Shut off compressed air.**
- f. Check basic the adjustment of the valve position indicator.
- The shift points can be adjusted by turning the positioning screws in the control unit.

12. Einbauvorrichtung

12.1 Assembly tool for seat seal

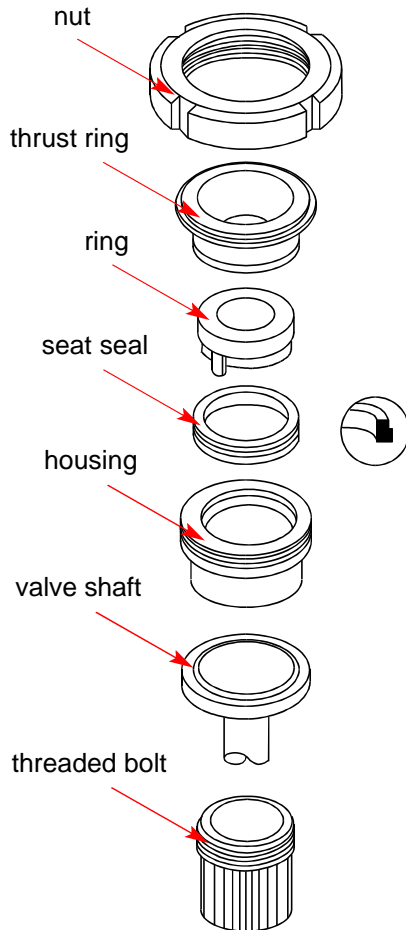

The assembly tool consists of:

- nut
- thrust ring
- ring with venting nose
- housing
- threaded bolt.

Installation of the seat seal in the valve shaft

1. Insert the valve shaft into the housing in such a way that the seal groove is in the housing.
2. Clamp the shaft into the housing by means of the threaded bolt. Clamp the housing into a vice.
3. Slightly grease the seat seal with APV food-grade grease. Then install the seal on the ring with the venting nose until it stops.
4. Introduce the ring with the installed seat seal into the housing and press it down until it stops sensibly.
5. Insert the thrust ring into the housing. Screw on the nut and tighten it with a hook spanner until it stops.
6. Release the nut. Take the ring and thrust ring off the housing.
7. Take the housing out of the vice, take off the threaded bolt. Detach the valve shaft from the housing.

Check the even fit of the seat seal.

Assembly tool for seat seal

To simplify the installation of the seat seal, the following assembly tools are available:

Assembly tool SW4		
DN	Inch	ref.No.:
50	2"	51-13-112/17
	2,5"	51-13-120/17
65	3"	51-13-113/17
80		51-13-121/17
100	4"	51-13-114/17
		51-13-115/17

13. Trouble Shooting

Failure	Remedy
Valve closed and pressure in upper housing	
Valve is untight	Replace seat seals. Check line pressure: Permissible line pressure see 7.
Leakage in the area of the clamp	Replace housing seals.
Leakage at the upper valve shaft in the area of the valve yoke	Replace shaft seal, seat seal and guide bush.
Actuator	
Air escapes from the actuator rod	Replace complete seal screw for actuator.
Actuator does not work (air escapes permanently from the venting plug)	Replace complete actuator.
Valve position indication	
Feedback is missing	Carry out fine adjustment.

14. Spare Parts Lists

The reference numbers of the spare parts for the different valve designs and sizes are included in the attached spare parts drawings with corresponding lists.

Please indicate the following data to place an order for spare parts:

- number of required parts
- reference number
- designation.

Data are subject to change.

To order a complete new SW4 valve, please use the the corresponding ordering sheet.

**DELTA SW4 - VALVE PROGRAMME
ORDERING SHEET FOR SW4 VALVES WITH FITTINGS**

BA SW4LH 00002
ID-No.: H 3 1 9 1 7 2
Translation of original manual



rev. 0



Your local contact:



APV
Zeichenstraße 49
D-59425 Unna

Phone: +49(0) 23 03/ 108-0 Fax: +49(0) 23 03 / 108-210

For more information about our worldwide locations, approvals, certifications, and local representatives, please visit www.apv.com.

Copyright © 2008 SPX Corporation

The information contained in this document, including any specifications and other product details, are subject to change without notice. While we have taken care to ensure the information is accurate at the time of going to press, we assume no responsibility for errors or omissions nor for any damages resulting from the use of the information contained herein.



14.1 Ventil / Valve DN 50 - 100

DELTA SW4 Langhub / Long-stroke

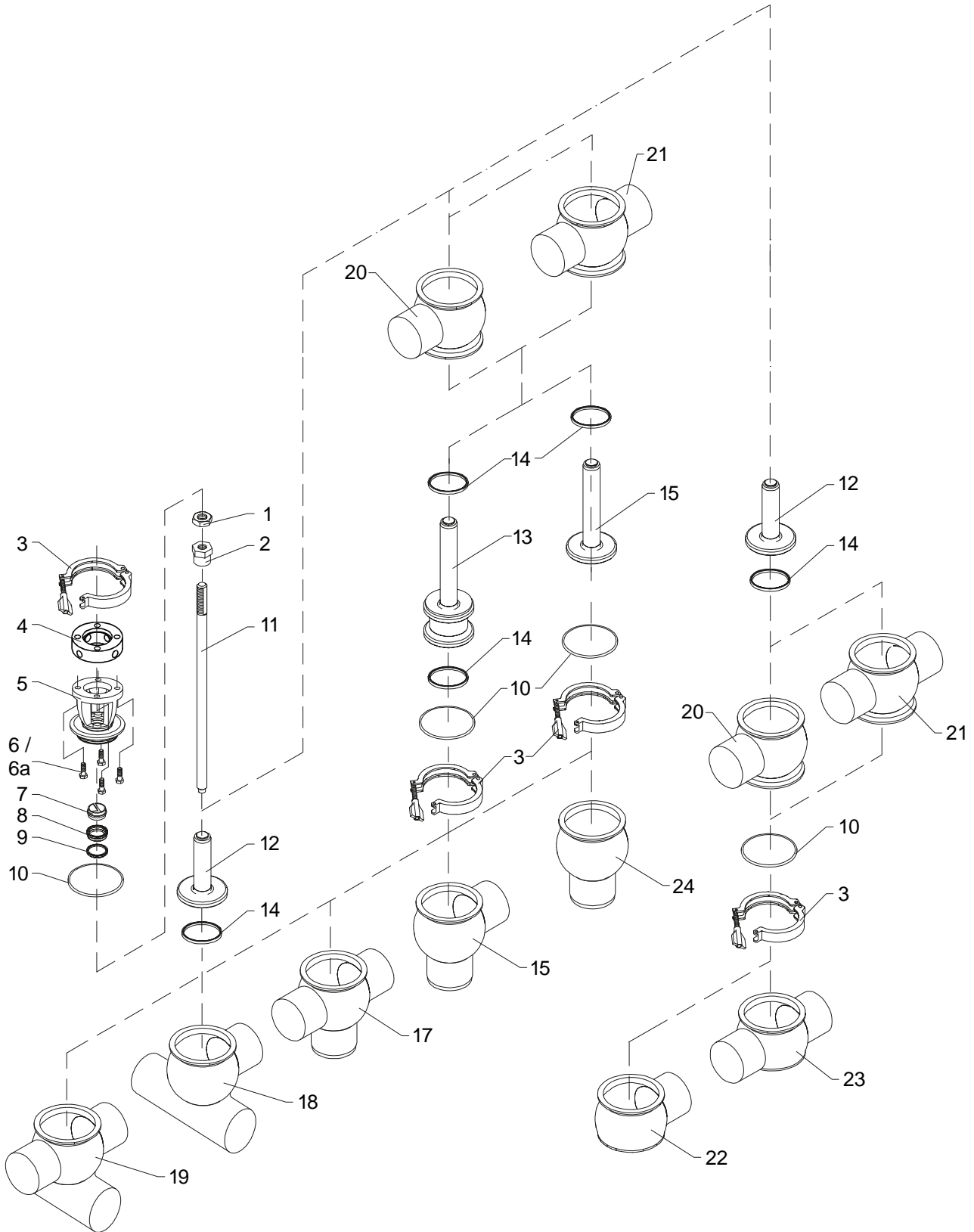

14.1 Ventil / Valve DN 50 - 100

DELTA SW4 Langhub / Long-stroke

Pos.	Stk./Qty.	Benennung	Description	DN 50	DN 65	DN 80	DN 100
				Ws. - Nr. / Part No.			
1	1	Skt. Mutter M12	Nut M12	65-50-101/15	65-50-101/15	65-50-101/15	65-50-101/15
2	1	Zentrierscheibe SW4	Center washer SW4	15-28-940/12	15-28-940/12	15-28-940/12	15-28-940/12
3	1-2	Gelenkklemme	Clamp	42-40-437/12	42-40-487/12	42-40-537/12	42-40-637/17
4	1	Adapter SW4 - Langhub	Adapter SW4 long-stroke	08-48-374/17	08-48-374/17	08-48-376/17	08-48-375/17
5	1	Laterne	Yoke	15-40-962/47	15-40-963/47	15-40-966/47	15-40-967/47
6	4	Zyl. Schraube M8x32	Cap Screw M8x32			65-05-124/13	65-05-124/13
6a	4	Skt. Schraube	Screw	DIN EN 933-M8x35-A2-70		DIN EN 933-M8x20-A2-70	
7	1	Führungsbuchse	Bushing	08-01-178/23	08-01-178/23	08-01-178/23	08-01-178/23
8	1	Schaftdichtung	Shaft seal	58-33-150/23	58-33-150/23	58-33-150/23	58-33-150/23
9	1	Tellerdichtung*	Seat seal	58-33-293/**	58-33-293/**	58-33-293/**	58-33-293/**
10	1-2	Gehäusedichtung*	Housing seal	58-33-124/**	58-33-442/**	58-33-492/**	58-33-127/**
11	1	Zugstange SW4-Langhub	Guide rod SW4 long-stroke	15-23-870/12	15-23-870/12	15-23-871/12	15-23-871/12
12	1	Schaft SW41	Shaft SW41	15-25-428/42	15-25-478/42	15-25-528/42	15-25-628/42
13	1	Schaft SW43 - Langhub	Shaft SW43 long-stroke	15-25-166/42	15-25-167/42	15-25-168/42	15-25-169/42
14	1-2	Tellerdichtung*	Seat seal	58-33-443/**	58-33-493/**	58-33-543/**	58-33-643/**
15	1	Schaft SWT4 - Langhub	Shaft SWT4 long-stroke	15-25-213/42	15-25-214/42	15-25-215/42	15-25-216/42
16	1	Gehäuse SW41	Housing SW41	15-60-440/47	15-60-490/47	15-60-540/47	15-60-640/47
17	1	Gehäuse SW42	Housing SW42	15-61-440/47	15-61-490/47	15-61-540/47	15-61-640/47
18	1	Gehäuse SWE43	Housing SWE43	15-66-430/47	15-66-480/47	15-66-530/47	15-66-630/47
19	1	Gehäuse SWE44	Housing SWE44	15-67-430/47	15-67-480/47	15-67-530/47	15-67-630/47
20	1	Geh.-Oberteil SW43	Hous.-upp. part SW43	15-62-003/47	15-62-004/47	15-62-005/47	15-62-006/47
21	1	Geh.-Oberteil SW44	Hous.-upp. part SW44	15-63-003/47	15-63-004/47	15-63-005/47	15-63-006/47
22	1	Geh.-Untert. SWE41	Hous.-low.part SWE41	15-60-102/47	15-60-103/47	15-60-104/47	15-60-105/47
23	1	Geh.-Untert. SWE48	Hous.-low.part SWE48	15-65-431/47	15-65-481/47	15-65-531/47	15-65-631/47
24	1	Kugelring SW41	Ball ring SW41	15-60-092/47	15-60-093/47	15-60-094/47	15-60-095/47

** /33: HNBR; /73: FPM (Viton); /93: EPDM; /13: VMQ**

*** Wenn die Tellerdichtung in VMQ ist, wird die Gehäusedichtung (Pos.9) in HNBR eingesetzt.
When seat seals are made of VMQ (silicone), the body seal (pos. 9) is to be made of HNBR

* Dichtungssatz für SW41 + SW42 / SWE43+ SWE44
Seal kit for SW41 + SW42 / SWE43+ SWE44

Pos.	Stk./Qty.	Benennung	Description	50	65	80	100
				Ws. - Nr. / Part No.			
	1	Dichtungssatz FPM	Seal kit FPM	58-34-702/00	58-34-703/00	58-34-704/00	58-34-705/00
	1	Dichtungssatz EPDM	Seal kit EPDM	58-34-702/01	58-34-703/01	58-34-704/01	58-34-705/01
	1	Dichtungssatz VMQ	Seal kit VMQ	58-34-702/02	58-34-703/02	58-34-704/02	58-34-705/02
	1	Dichtungssatz HNBR	Seal kit HNBR	58-34-702/06	58-34-703/06	58-34-704/06	58-34-705/06

* Dichtungssatz für SWE41 + SWE42
Seal kit for SWE41 + SWE42

Pos.	Stk./Qty.	Benennung	Description	50	65	80	100
				Ws. - Nr. / Part No.			
	1	Dichtungssatz FPM	Seal kit FPM	58-34-717/00	58-34-718/00	58-34-719/00	58-34-720/00
	1	Dichtungssatz EPDM	Seal kit EPDM	58-34-717/01	58-34-718/01	58-34-719/01	58-34-720/01
	1	Dichtungssatz VMQ	Seal kit VMQ	58-34-717/02	58-34-718/02	58-34-719/02	58-34-720/02
	1	Dichtungssatz HNBR	Seal kit HNBR	58-34-717/06	58-34-718/06	58-34-719/06	58-34-720/06

* Dichtungssatz für SW43 + SW44
Seal kit for SW43 + SW44

Pos.	Stk./Qty.	Benennung	Description	50	65	80	100
				Ws. - Nr. / Part No.			
	1	Dichtungssatz FPM	Seal kit FPM	58-34-732/00	58-34-733/00	58-34-734/00	58-34-735/00
	1	Dichtungssatz EPDM	Seal kit EPDM	58-34-732/01	58-34-733/01	58-34-734/01	58-34-735/01
	1	Dichtungssatz VMQ	Seal kit VMQ	58-34-732/02	58-34-733/02	58-34-734/02	58-34-735/02
	1	Dichtungssatz HNBR	Seal kit HNBR	58-34-732/06	58-34-733/06	58-34-734/06	58-34-735/06

14.2 Ventil / Valve Zoll / Inch 2"-4" DELTA SW4 Langhub / Long-stroke

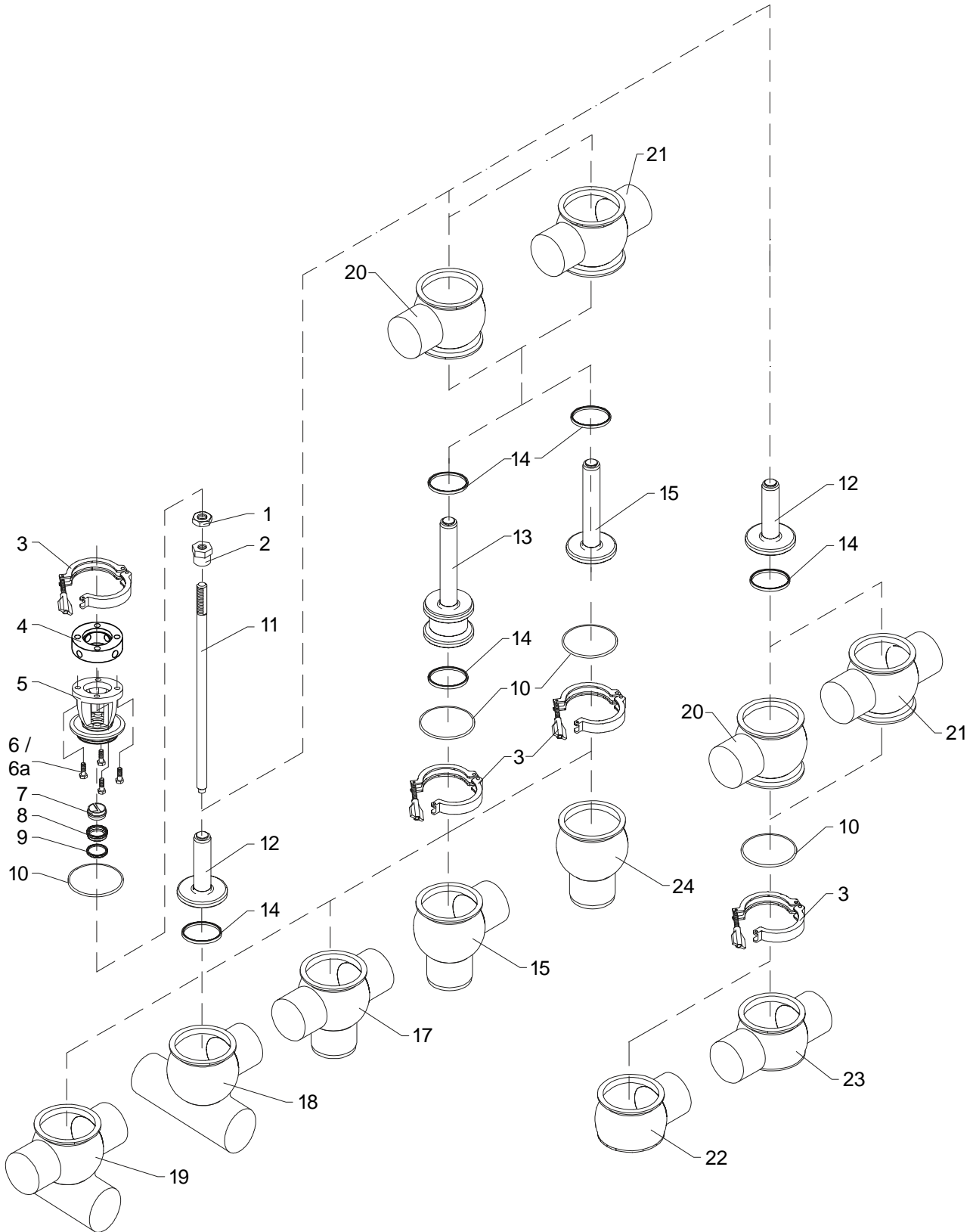

14.2 Ventil Zoll / Inch 2" - 4"

DELTA SW4 Langhub / Long-stroke

Pos.	Stk./Qty.	Benennung	Description	2"	2,5"	3"	4"
				Ws. - Nr. / Part No.			
1	1	Skt. Mutter M12	Nut M12	65-50-101/15	65-50-101/15	65-50-101/15	65-50-101/15
2	1	Zentrierscheibe SW4	Center washer SW4	15-28-940/12	15-28-940/12	15-28-940/12	15-28-940/12
3	1-2	Gelenkklemme	Clamp	42-40-437/12	42-40-487/12	42-40-537/12	42-40-637/17
4	1	Adapter SW4 - Langhub	Adapter SW4 long-stroke	08-48-374/17	08-48-374/17	08-48-376/17	08-48-375/17
5	1	Laterne	Yoke	15-40-962/47	15-40-964/47	15-40-965/47	15-40-967/47
6	4	Zyl. Schraube M8x32	Cap Screw M8x32			65-05-124/13	65-05-124/13
6a	4	Skt. Schraube	Screw	DIN EN 933-M8x35-A2-70		DIN EN 933-M8x20-A2-70	
7	1	Führungsbuchse	Bushing	08-01-178/23	08-01-178/23	08-01-178/23	08-01-178/23
8	1	Schaftdichtung	Shaft seal	58-33-150/23	58-33-150/23	58-33-150/23	58-33-150/23
9	1	Tellerdichtung*	Seat seal	58-33-293/**	58-33-293/**	58-33-293/**	58-33-293/**
10	1-2	Gehäusedichtung*	Housing seal	58-33-124/**	58-33-125/**	58-33-126/**	58-33-127/**
11	1	Zugstange SW4-Langhub	Guide rod SW4 long-stroke	15-23-870/12	15-23-870/12	15-23-871/12	15-23-871/12
12	1	Schaft SW41	Shaft SW41	15-25-453/42	15-25-503/42	15-25-553/42	15-25-653/42
13	1	Schaft SW43 - Langhub	Shaft SW43 long-stroke	15-25-172/42	15-25-173/42	15-25-174/42	15-25-175/42
14	1-2	Tellerdichtung*	Seat seal	58-33-443/**	58-33-109/**	58-33-568/**	58-33-643/**
15	1	Schaft SWT4 - Langhub	Shaft SWT4 long-stroke	15-25-203/42	15-25-204/42	15-25-205/42	15-25-206/42
16	1	Gehäuse SW41	Housing SW41	15-60-465/47	15-60-515/47	15-60-565/47	15-60-665/47
17	1	Gehäuse SW42	Housing SW42	15-61-465/47	15-61-515/47	15-61-565/47	15-61-665/47
18	1	Gehäuse SWE43	Housing SWE43	15-66-455/47	15-66-505/47	15-66-555/47	15-66-655/47
19	1	Gehäuse SWE44	Housing SWE44	15-67-455/47	15-67-505/47	15-67-555/47	15-67-655/47
20	1	Geh.-Oberteil SW43	Hous.-upp. part SW43	15-62-012/47	15-62-013/47	15-62-014/47	15-62-015/47
21	1	Geh.-Oberteil SW44	Hous.-upp. part SW44	15-63-012/47	15-63-013/47	15-63-014/47	15-63-015/47
22	1	Geh.-Untert. SWE41	Hous.-low.part SWE41	15-60-112/47	15-60-113/47	15-60-114/47	15-60-115/47
23	1	Geh.-Untert. SWE48	Hous.-low.part SWE48	15-65-456/47	15-65-506/47	15-65-556/47	15-65-656/47
24	1	Kugelring SW41	Ball ring SW41	15-60-085/47	15-60-086/47	15-60-087/47	15-60-088/47

** /33: HNBR; /73: FPM (Viton); /93: EPDM; /13: VMQ***

*** Wenn die Tellerdichtung in VMQ ist, wird die Gehäusedichtung (Pos.9) in HNBR eingesetzt.
When seat seals are made of VMQ (silicone), the body seal (pos. 9) is to be made of HNBR

* Dichtungssatz für SW41 + SW42 / SWE43+ SWE44
Seal kit for SW41 + SW42 / SWE43+ SWE44

Pos.	Stk./Qty.	Benennung	Description	2"	2,5"	3"	4"
				Ws. - Nr. / Part No.			
	1	Dichtungssatz FPM	Seal kit FPM	58-34-702/00	58-34-710/00	58-34-711/00	58-34-705/00
	1	Dichtungssatz EPDM	Seal kit EPDM	58-34-702/01	58-34-710/01	58-34-711/01	58-34-705/01
	1	Dichtungssatz VMQ	Seal kit VMQ	58-34-702/02	58-34-710/02	58-34-711/02	58-34-705/02
	1	Dichtungssatz HNBR	Seal kit HNBR	58-34-702/06	58-34-710/06	58-34-711/06	58-34-705/06

* Dichtungssatz für SWE41 + SWE42
Seal kit for SWE41 + SWE42

Pos.	Stk./Qty.	Benennung	Description	2"	2,5"	3"	4"
				Ws. - Nr. / Part No.			
	1	Dichtungssatz FPM	Seal kit FPM	58-34-717/00	58-34-725/00	58-34-726/00	58-34-720/00
	1	Dichtungssatz EPDM	Seal kit EPDM	58-34-717/01	58-34-725/01	58-34-726/01	58-34-720/01
	1	Dichtungssatz VMQ	Seal kit VMQ	58-34-717/02	58-34-725/02	58-34-726/02	58-34-720/02
	1	Dichtungssatz HNBR	Seal kit HNBR	58-34-717/06	58-34-725/06	58-34-726/06	58-34-720/06

* Dichtungssatz für SW43 + SW44
Seal kit for SW43 + SW44

Pos.	Stk./Qty.	Benennung	Description	2"	2,5"	3"	4"
				Ws. - Nr. / Part No.			
	1	Dichtungssatz FPM	Seal kit FPM	58-34-732/00	58-34-740/00	58-34-741/00	58-34-735/00
	1	Dichtungssatz EPDM	Seal kit EPDM	58-34-732/01	58-34-740/01	58-34-741/01	58-34-735/01
	1	Dichtungssatz VMQ	Seal kit VMQ	58-34-732/02	58-34-740/02	58-34-741/02	58-34-735/02
	1	Dichtungssatz HNBR	Seal kit HNBR	58-34-732/06	58-34-740/06	58-34-741/06	58-34-735/06

14.3 Steuerkopf / Actuator

DELTA SW4 Langhub / Long-stroke

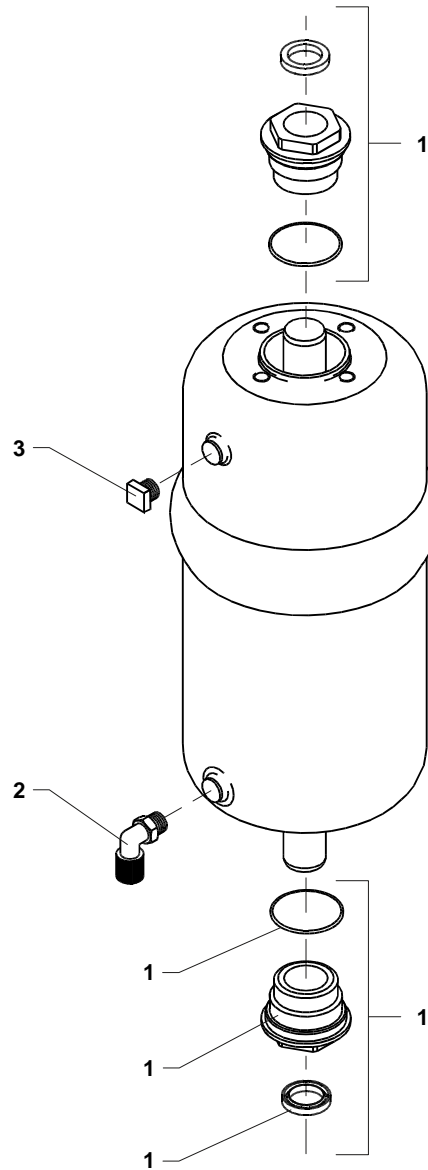

Pos.	Stk./Qty.	Benennung	Description	Ø110	Ø165
				Ws.-Nr. / Part No.	
-	-	Steuerkopf - Langhub komplett	Actuator - long-stroke complete	15-32-090/17	15-32-091/17
-	-	Steuerkopf - Langhub kpl. - Luft/Luft	Actuator - long-stroke cpl. Air/Air	15-32-095/17	15-32-096/17
1	2	Dichtungsschraube mit O-ring und V-Dichtung	Seal bearing with O-ring and V-seal	15-28-845/93	15-28-845/93
2*	1-2	Winkelverschraubung G1/8"	Elbow Connector G1/8"	08-60-750/93	08-60-750/93
3	1	Stopfen	Plug	08-60-005/93	08-60-005/93

* Der Steuerkopf kpl. und Steuerkopf kpl. Luft / Luft ist standardmäßig mit 2 x Winkelverschraubungen ausgerüstet.

* The actuator cpl. and actuator cpl. air/ air is designed with 2 x Elbow connector by standard.

14.4 Ventilstellungsmeldung mit Initiatorenhalterung / SW4 - Langhub Proximitybox with switch holder / SW4 Long-stroke

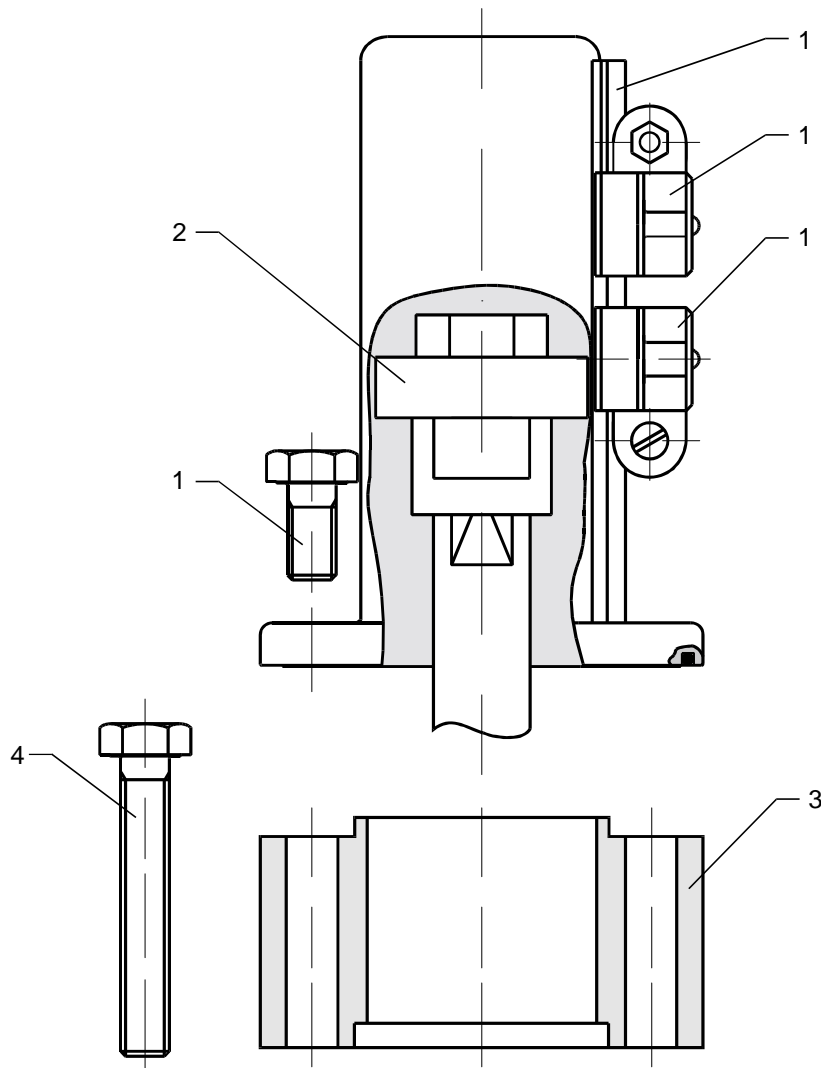

Pos.	Stk./Qty.	Benennung	Description	Ws.-Nr. / Part No.
1	1	Ventilstellungsmeldung kpl.	Complete Proximitybox	15-33-932/93
2	1	Schaltnocke	Actuator screw	08-52-291/97
3*	1	Adapter SW4 - 165 VSM Langhub	Adapter SW4 - 165 PSH long-stroke	08-48-360/93
4*	4	Skt. Schraube M8x50	hex. screw M8x50	65-01-092/15

* Adapter und Skt. Schrauben werden nur bei den Ventilgrößen DN80-100 / 3"-4" benötigt.

* Adapter and hex. screws are only necessary for valve dimension DN 80-100 / 3"-4".